

# Assembly & Installation Guide

## elfa® Drawer Frame

### Basic Tools For Assembly and Installation

Please read all of the instructions before beginning assembly.

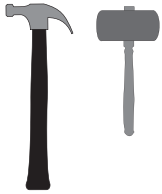

Hammer or  
Plastic Mallet



Wood block to  
protect the floor

### Drawer Frame Unit Components

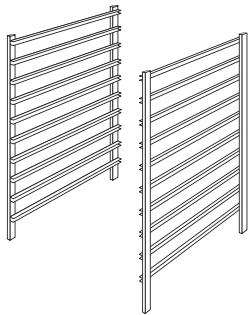

Frame Sides

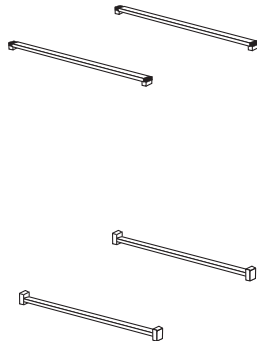

Crossbars Basic Set

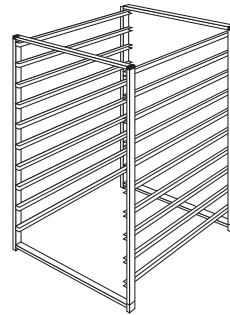

Frame

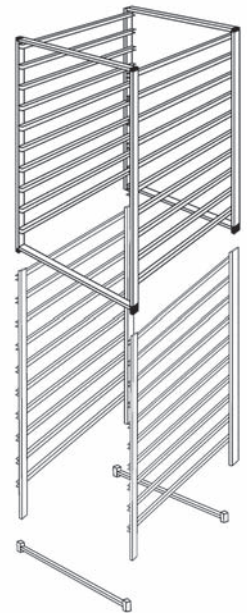

Crossbars  
Extra Bottom Set

An elfa® Drawer Frame Unit consists of the Frame and the Drawers that slide into the Frame. The Frame is made up of two Frame Sides and a set of four Crossbars.

### Drawer Frame Assembly



Use Frame Sides with the same height and the same depth.



Face the Runners towards each other.



Assemble with Crossbars.



Combine Frame Sides for a variety of heights.

## Drawer Frame Assembly

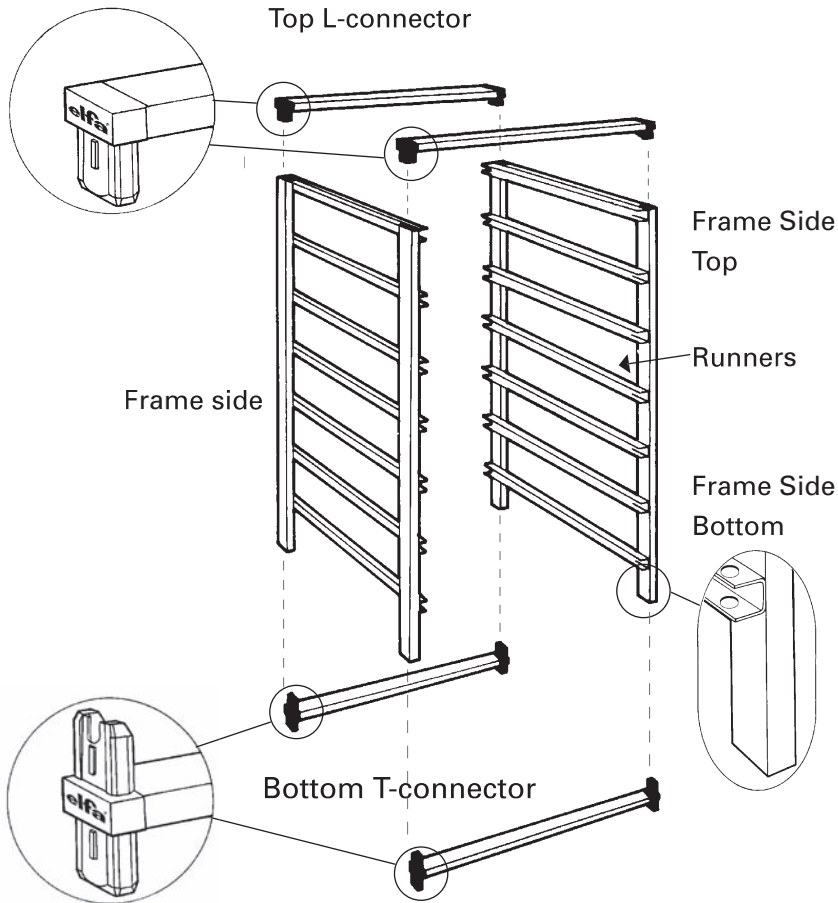

1. Tap the Bottom T-connectors into the bottom of each Frame Side. (Note: Runners should face inward.)
2. Tap the Top L-connectors into the top of each Frame Side.
3. Slide in the Drawers.



Use a wood block to protect the floor during assembly.



You can add Frame Feet to protect the floor.

## Combined Frames

elfa® Drawer Frames can be Combined for a Variety of Heights. Use Frames Sides of the same width.

1. Assemble Top Frame Sides completely, as shown above.
2. Assemble Bottom Frame Sides omitting Top L-connectors
3. Lower Top Frame Sides onto Bottom Frame Sides and secure by tapping each corner of the Top Frame Sides until it is completely locked into the Bottom Frame Sides.



Detailed installation guidelines follow the products.

Frames are available in three heights:  
440 mm (4-runner)  
740 mm (7-runner)  
1860 mm (10-runner).

There is no limit to the ways you can extend your drawer system.

